

Description

The RF-VCA is a configurable RF receiver providing flexible antenna to digital reception for RF signals up to 3GHz. The RF-VCA can be via-configured for a wide range of applications including: GPS, FM tuner, Cellular Basestations, DAB, DVB and military communications.

The array includes Kaben Wireless Silicon's patented Sampled IF ADC (SIF-ADC) technology which eliminates the need for external SAW filters thereby reducing system cost and board area.

The RF-VCA is implemented in a 65nm RF-CMOS process enabling the cost effective integration of baseband digital functions and microprocessors for low-cost consumer applications.

Applications

- GPS Receivers
- Basestation Receivers
- Repeaters
- Multi-channel FM Receivers
- DAB and DVB Receivers
- Military Radios
- Software Defined Radios
- Cognitive Radios
- MRI Receive Channels

Features

- Dual Antenna to Digital Conversion Paths
- DC to 3GHz Operation
- 65nm RF-CMOS Process
- Configurable LNA, Mixer and IIR Filters
- SIF-ADC
- Programmable filter transfer function
- 14-bit @ 156MSPS, 12.3 ENOB
- Dual Fractional-N Synthesizers
- No External IF SAW or Discrete Filters Required
- Optional JESD204B SERDES Interface
- 2 million gates of configurable logic
- 2 Mbits of distributed dual-port RAM



SIF-ADC Technology

At the core of the receiver is Kaben's patented SIF-ADC technology. The SIF-ADC is an analog implementation of a Finite Impulse Response (FIR) filter prior to a pipelined Analog to Digital Converter (ADC).

Applying the filter function prior to the ADC provides exceptional anti-alias and image reject filtering to prevent unwanted signals from compromising the ADC performance. The transfer function of each SIF filter is programmable using 256 field programmable tap coefficients.

RF-VCA Block Diagram

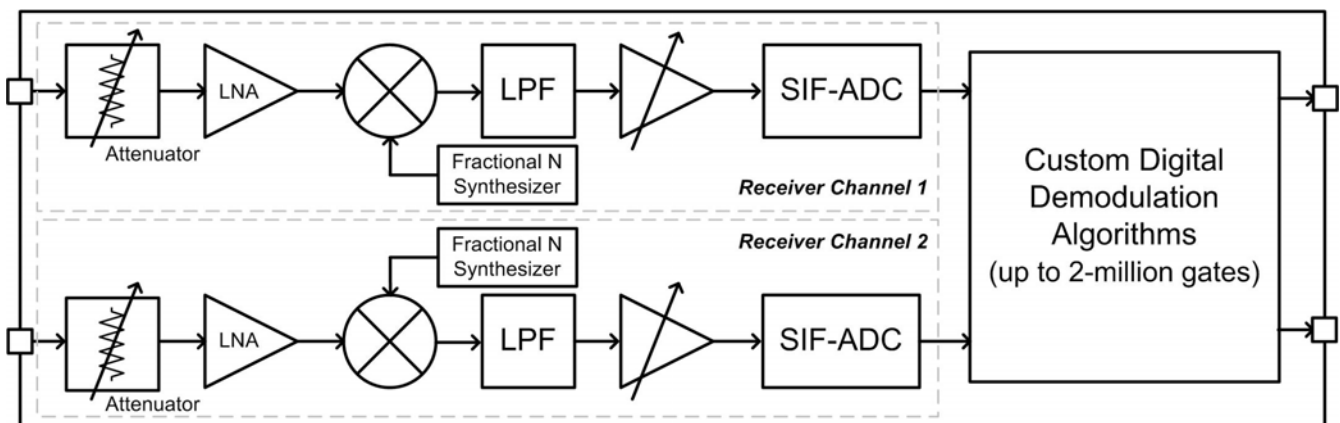

Creating an RF-VCA Tailored for Your Application

VCA's are the fast, inexpensive and proven way to create mixed-signal RF ASIC solutions.

Designing with VCAs enables going from concept to working silicon in months. VCA fabrication time is weeks instead of the three months typical of full-custom. By using the Kaben-Triad large IP library and growing family of VCAs, risk is minimized and time to working silicon is shortened. The RF-VCA can be via configured into a wide range of RF applications. The table below shows key performance characteristics for three of the possible RF configurations. The FM tuner represents a high dynamic range application, GPS a high sensitivity application and ISM a low power application.

Parameter	Conditions	FM Tuner	GPS	ISM	Units
Input Frequency		65 to 108	1575.42	902 to 928	MHz
Bandwidth		32	4	1	MHz
Input Power	27°C	17	-20	-10	dBm
IIP3		52	25	19	dB
Noise Figure		38	7.5	16.5	dB
Input Power	27°C	-10	-25	-20	dBm
IIP3		25	20	9	dB
Noise Figure		11	2.5	6.5	dB
Input Power	27°C *With off-chip matching	-15	-30	-25	dBm
IIP3		20	17	9	dB
Noise Figure		8.5 / 5*	1.6	4	dB
Anti-alias stop band attenuation		90	80	75	dB
Output		14	8	10	Bits
Sample Rate		125	102.4	4	MHz
INL		1	1	1	LSB
DNL		1	1	1	LSB
Power consumption	1.8V Supply	65	50	20	mW
Power consumption	1.0V Supply	200	150	50	mW

Field Programmable

Via-configurability allows an RF-VCA to be customized for a given application. The SIF-ADC and RF processing functions can also be configured to include field programmable features allowing for agile RF solutions with dynamically programmable features.

Advanced RF and Digital Integration

Using a 65nm process allows for a customer's digitally intensive algorithms to be implemented in the digital portion of the RF-VCA. An RF-VCA can easily combine a custom RF receiver with ARM processors, up to 2-million digital gates and over 2-Mbits of SRAM into a single-chip solution.

Talk with a Triad System Architect about Your Design

Need to turn your idea into a single-chip solution? Whether you have an idea, a working FPGA, discrete PCB schematic, or a full specification, our system architects are available to speak with you about your application and how we can help you turn your idea into your own RF-VCA. Our experienced engineering staff and operations team will support you from system design through prototyping and volume production delivery. Contact us by Email at info@triadsemi.com, by phone at 336-774-2150 or visit www.triadsemi.com.

Stay Up to Date on Triad Semiconductor Info

Visit support.triadsemi.com and register for product updates, browse the user forum and explore the knowledgebase.

Share this Info...

